

POWER RATING

Production tolerance : $\pm 3\%$

MODEL	CONDITIONS	POWER	rpm	Base Engine
L136	HEAVY DUTY	160PS (118kW)	2200	D1146

Note : 1) No reduction in rating for intake air temperature is up to 45 °C (318K) and sea water temperature is up to 32 °C (305K) , relative humidity is up to 60 % all data are based on operation to ISO 3046.

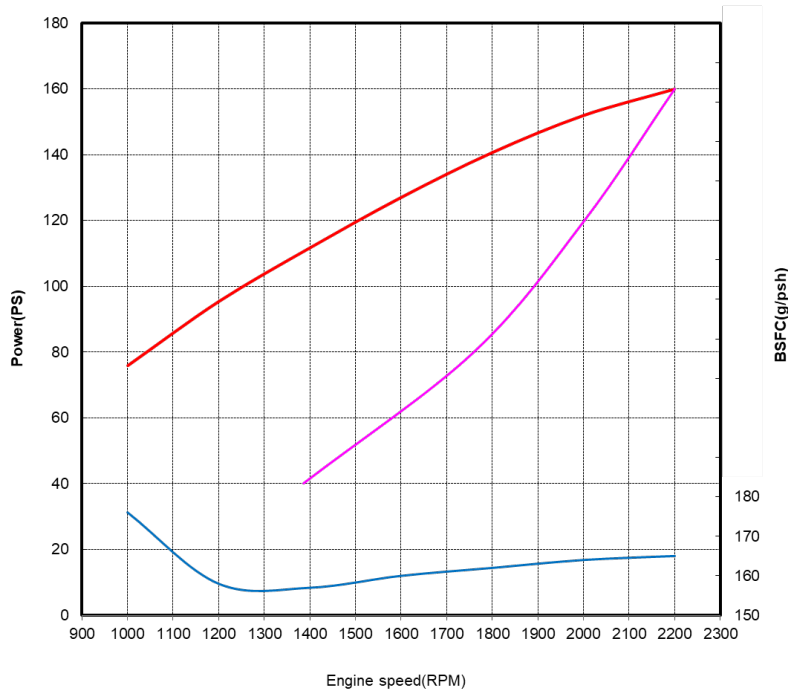
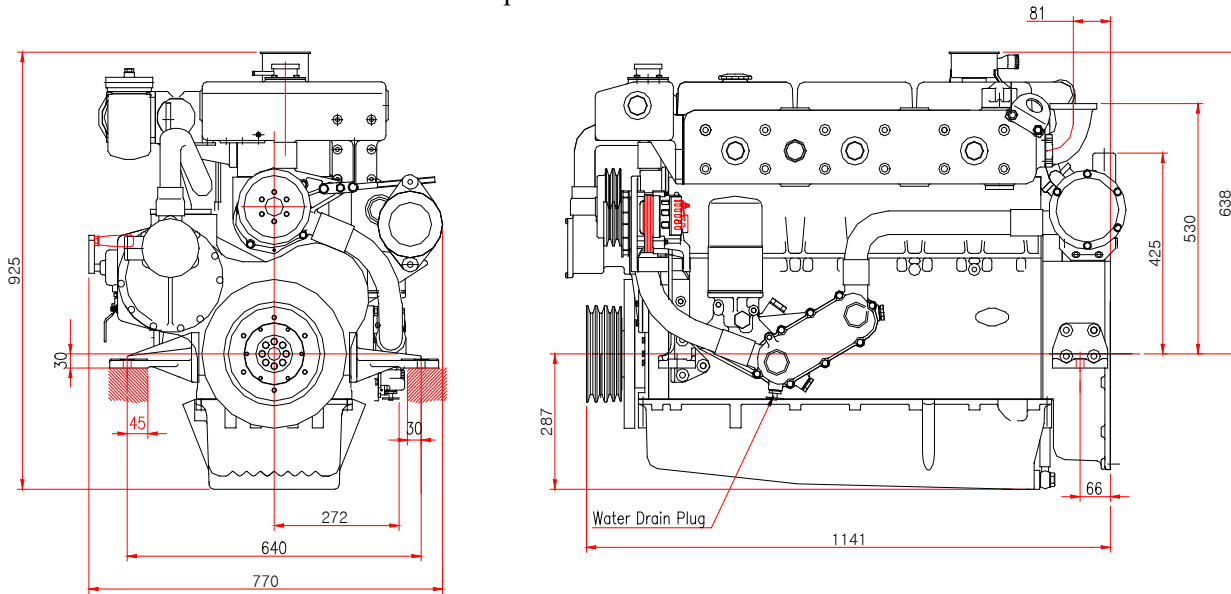

- Heavy Duty :** Operation hours are unlimited per year, at average load is up to 90 %, at full load is up to 80 %
 Typical gearbox ratio: 2.5 ~ 6
 (Fishing trawler, Tug boat, Pushing vessel, Cargo boat, Freighter, Ferry)

Engine Specification			
Model		Units	L136
Engine type			4 cycle, In line, direct- injection, water cooled, aspirated naturally
Rating output (B.H.P)		PS(kW)/rpm	160(118)/2200
Displacement		cc	8,071
Cylinder number - bore(φ) x stroke		mm	6 - φ111 x 139
Valve clearance at cold	In / Ex	mm	0.3 / 0.3
Low idling rpm		rpm	725 ± 25
No load max. rpm		rpm	below 2,420
Mean effective pressure		kg/cm ²	8.07
Mean piston speed		m/sec.	10.19
Compression ratio			17.6 : 1
Firing order			1 - 5 - 3 - 6 - 2 - 4
Compression pressure	at 200 rpm	kg/cm ²	28 (Initial Condition)
Governor type of injection pump			Mechanical all speed (R.S.V)
Fuel consumption		g/ps.h	165
		lit / h	32
Injection timing (B.T.D.C)		Deg	22° ± 1°
Fuel inj. nozzle opening pressure		kg/cm ²	214
Starting system			Electric Starting by starter motor
Starter motor capacity		V- kW	24 - 4.5
Alternator capacity		V- A	24 - 80
Battery		V- Ah	24 - 100
Cooling system			Indirect sea water cooling with heat exchanger
Cooling water capacity	Max. / Min.	lit	25 / 23
Fresh water pump type			Centrifugal type, driven by V- belt
Sea water pump type			Rubber impeller type driven by gear
Lubricating Oil (Engine)		pan capacity	lit
		pressure	kg/cm ²
Marine gear		Model	DMT90A (Dong-I)
		Gear ratio	1.61 2.06 2.45 2.82 3.12 3.46
Direction of revolution		crankshaft	Counter clockwise viewed from stern side
		propeller	Clockwise viewed from stern side
Engine size (L x W x H)		without M/G	mm
		with M. gear	mm
Engine dry weight		without M/G	kg
		with M. gear	kg

psi = kg/cm² x 14.22
 lb/ft. = N.m x 0.737
 kW = 0.2388 kcal/s

lb= kg x 2.205
 lb/PS.h = g/kW.h x 0.00162
 cfm = m³/min x 35.3

hp = PS x 0.98635
 U.S gal. = liter x 0.264

Head office
 7-11, Hwasu-Dong, Dong-Gu, Incheon, Korea
 TEL : 82-32-211-2246, 2248 FAX : 82-32-761-2759
Seoul Office
 Doosan Infracore Co. Ltd.,
 21st Floor, Doosan Tower, 18-12, Euljiro 6-ga, Jung-gu,
 Seoul, Korea.
 TEL : 82-2-3398-8521~8536 FAX : 82-2-3398-8509
 Web site : www.doosaninfracore.com

※ Specifications are subject to change without prior notice.